

Additions to Rev 4:
 7/20/06: Add 8 pin header for programming PLD

Title		PHYSICS ELECTRONICS SHOP	
LUNAR LASER RANGING		APOLLO Clock Slicer Circuitry	
Size	Document Number	Rev	
C	PHY-TM-P050824-S1(PES 030401)	4	
Date:	Thursday, October 05, 2006	Sheet	1 of 2

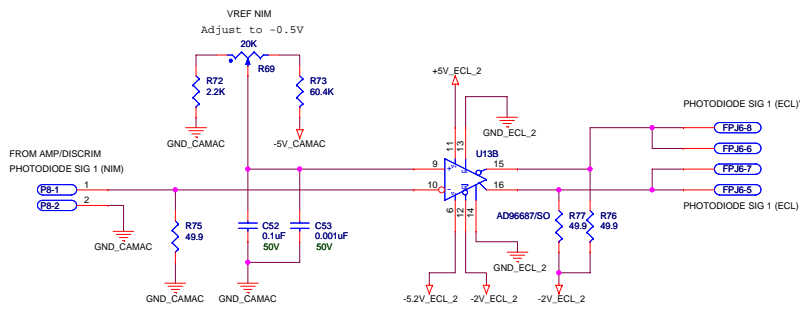

ANY SIGNALS ON FPJ6 SHOULD BE REFERENCED TO GND_ECL_2

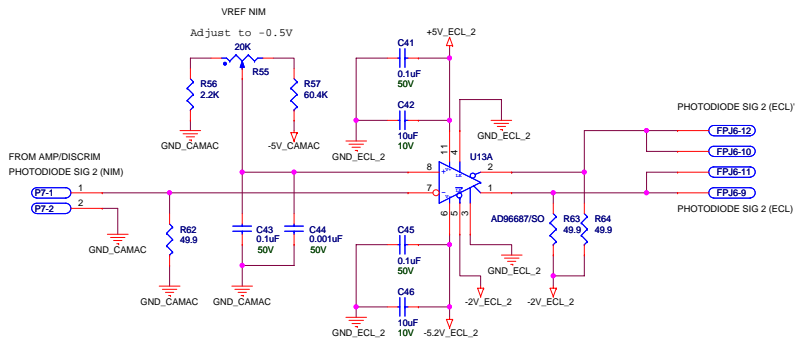

Locate jumper block close to power input.

